

The logo for LeadSolar features the word "Lead" in a bold, black, sans-serif font, followed by "Solar" in a grey, sans-serif font. The letter "S" in "Solar" is replaced by a green circular icon containing a white stylized sun with rays extending from the bottom right.

LeadSolar

*LS-600 & LS-600X
Microinverter Residential
System Design*

- Evaluate the site's energy needs to obtain the total kWhs for offset.
- Determine the PV DC system size using programs such as PVWatts. <http://pvwatts.nrel.gov/pvwatts.php>
- Select the PV module.
 - LS600: Modules with STC 230-400W (60 or 72 cell).
 - LS600X: Modules with STC 330-400W (96 cell).
- Determine the number of modules needed:
DC kW system size ÷ STC module rating
- Determine the number of inverters required: # Modules ÷ 2
- The LS600 comes with PLC or Zigbee communications.
- The LS600X comes with Zigbee only.

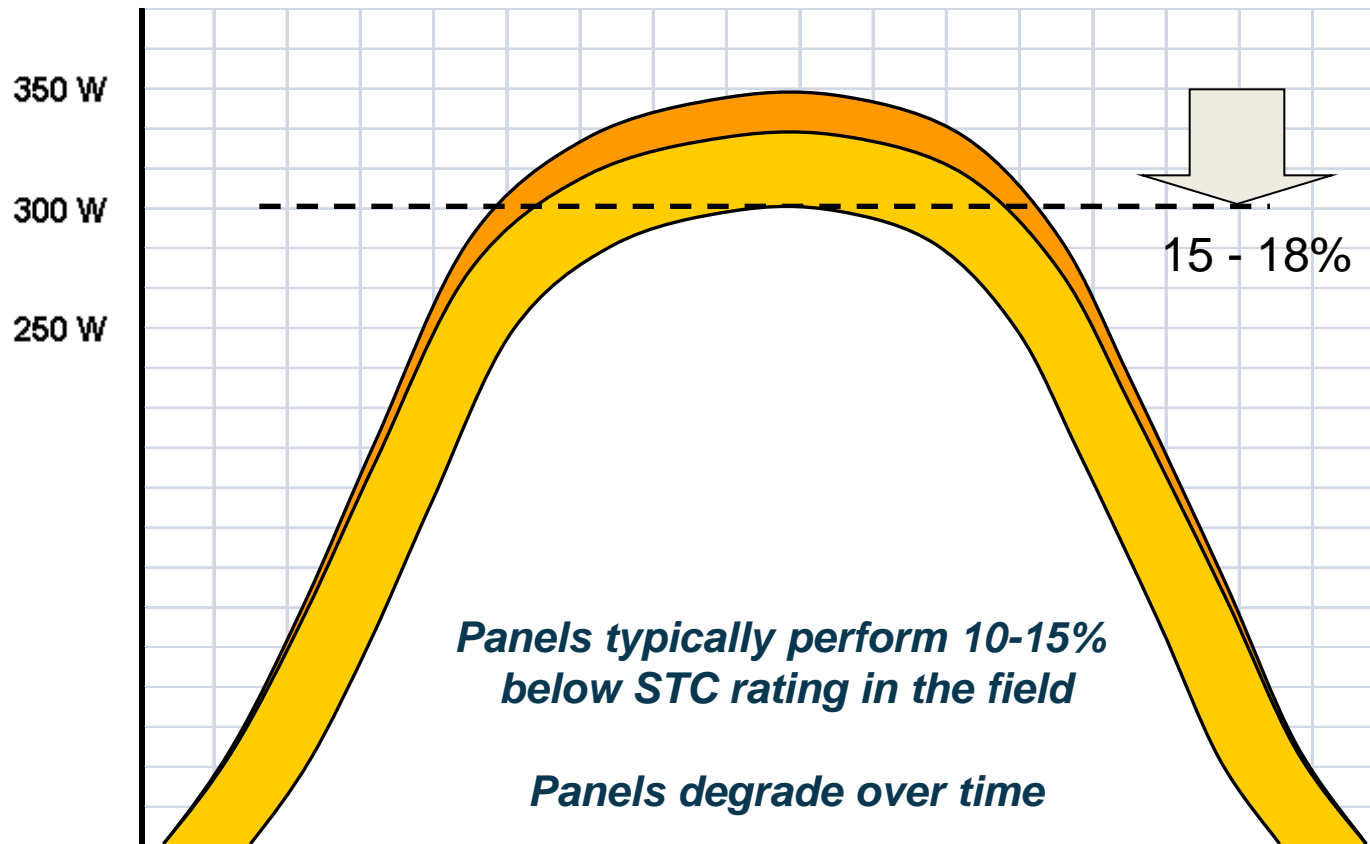

PV modules are typically oversized by 15-18% of inverter capacity with respect to their STC rating.

- LeadSolar microinverters connect to form AC branch circuits.

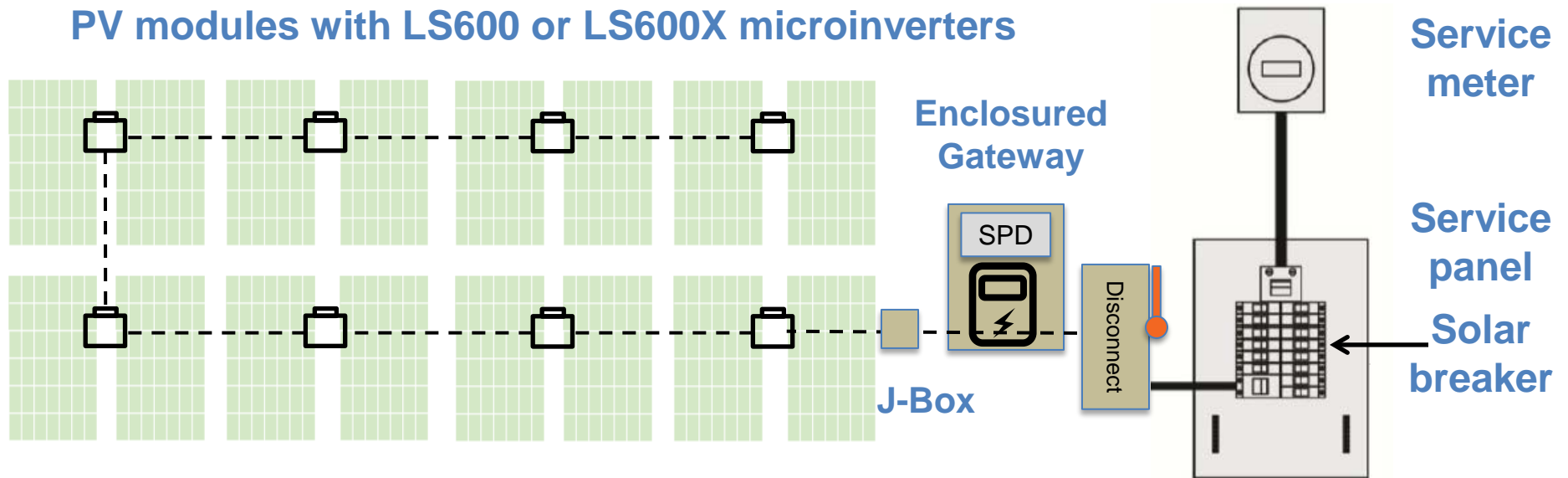

- LeadSolar microinverters can be configured as follows:
 - LS600-P: One 20A branch circuit will support up to 16 PV Modules (8 micros*)
 - LS600-Z: One 30A branch circuit will support up to 24 PV Modules (12 micros*)
 - LS600X: One 30A branch circuit will support up to 20 PV Modules (10 micros*)
- * With current limited outputs
- Installation of a Surge Protection Device (SPD) is recommended

- 100 A service panel \Rightarrow supports (1) 20 A branch circuit.
- 200 or 225 A service panel \Rightarrow typically supports 2 or 3 20/30 A branch circuits. (See LeadSolar Technical Bulletin on Branch Circuit sizing)
- Some utilities allow for a Generation Meter Adapter (GMA) which bypasses the main service panel.
- Dual branches to be combined in a subpanel with dedicated breaker in the main service panel.
- The PV system and electrical connections must be described by a Single Line Diagram (SLD).

Voltage Rise

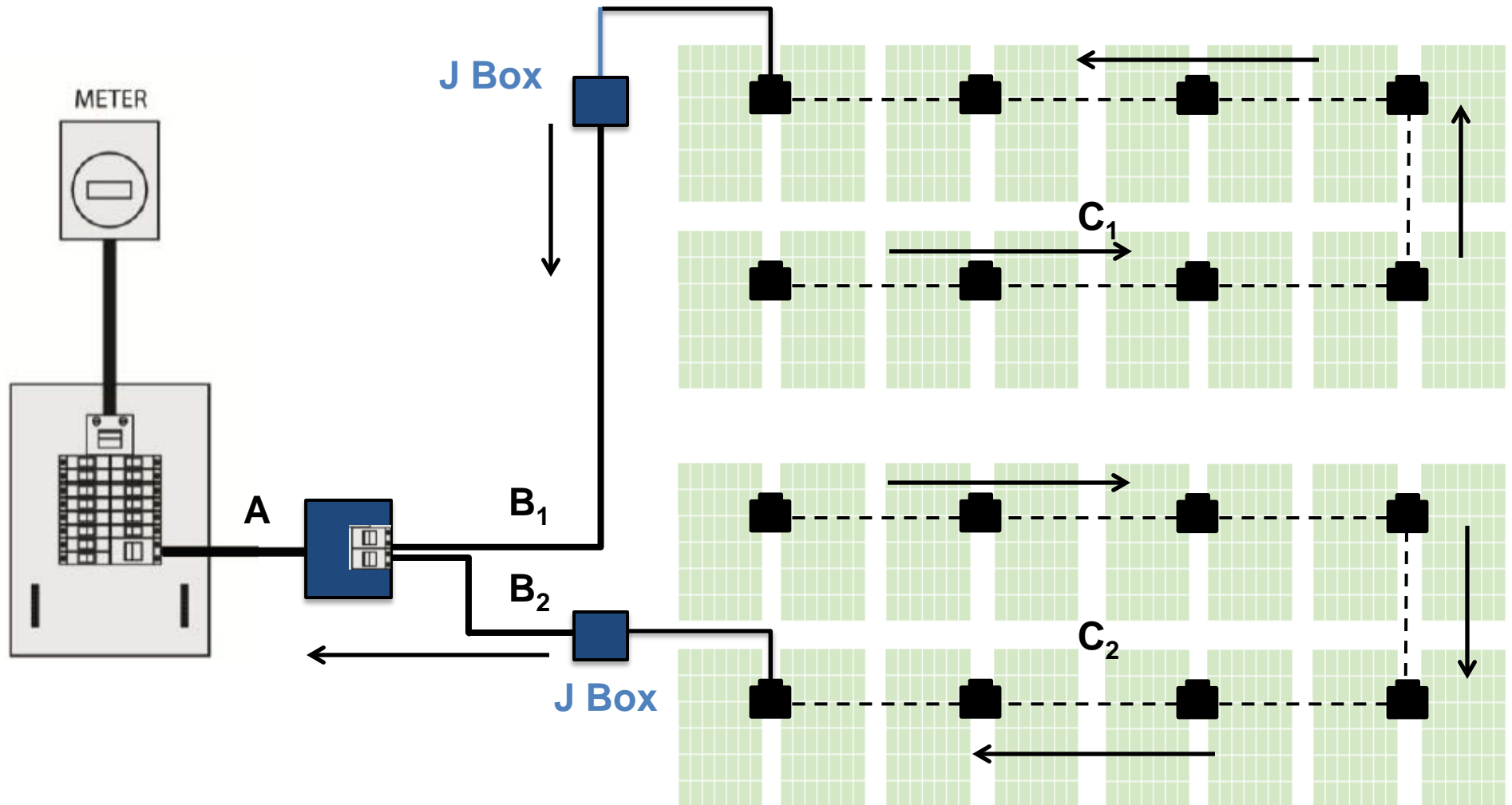

Total of all voltage rises from last inverter to main service panel for each branch must not exceed 2%: $A + B_1 + C_1 < 2\%$ and $A + B_2 + C_2 < 2\%$

For full branches "C" is approximately 1.5%

Voltage Rise – Center Tap

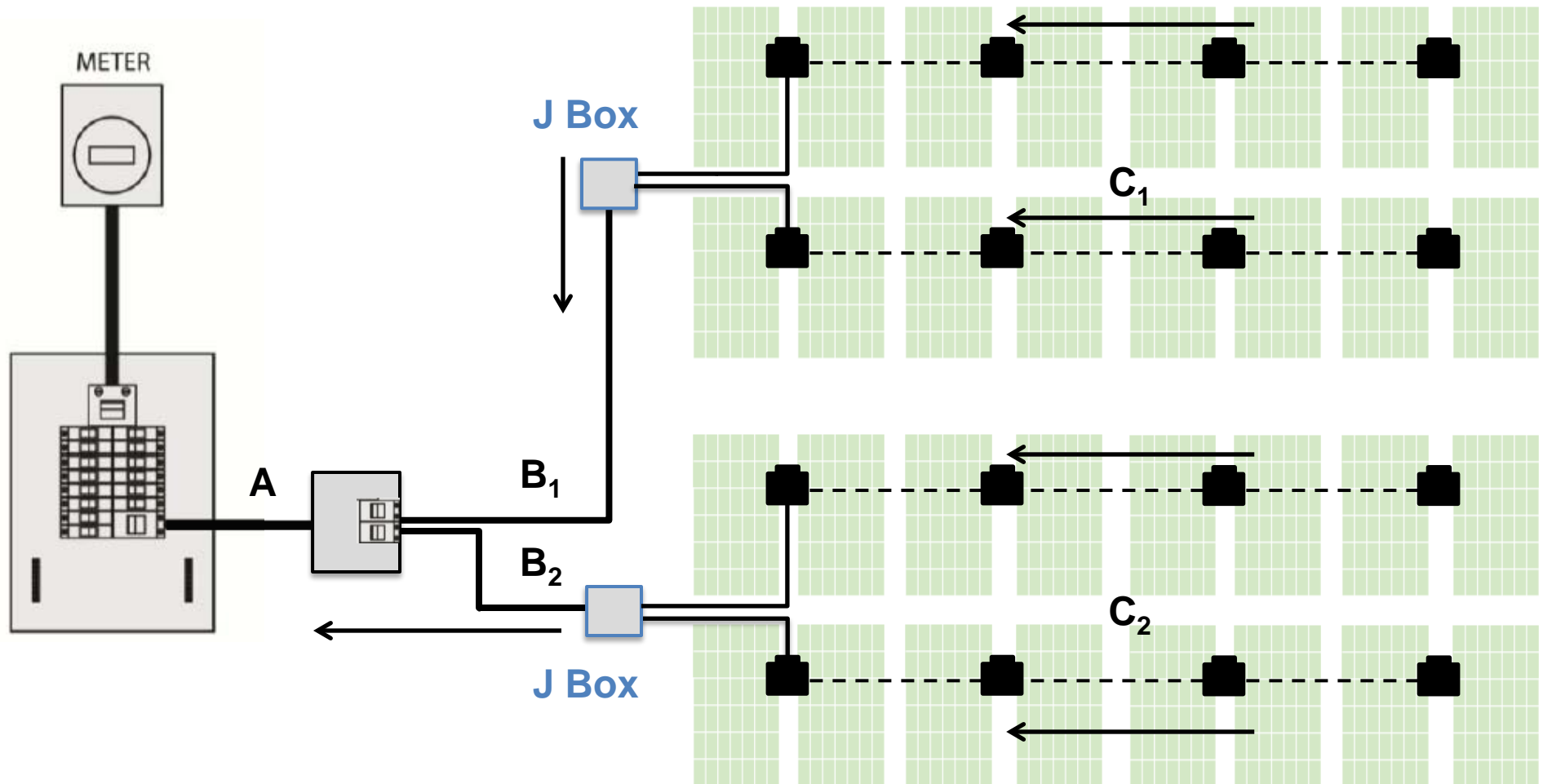

By center tapping, "C" now drops to 0.5%. Appropriate AWG wire sizing for "A" and "B" can be determined via a voltage rise/drop calculator such as:

<http://www.southwire.com/support/voltage-drop-calculator.htm>

Voltage Rise – Example

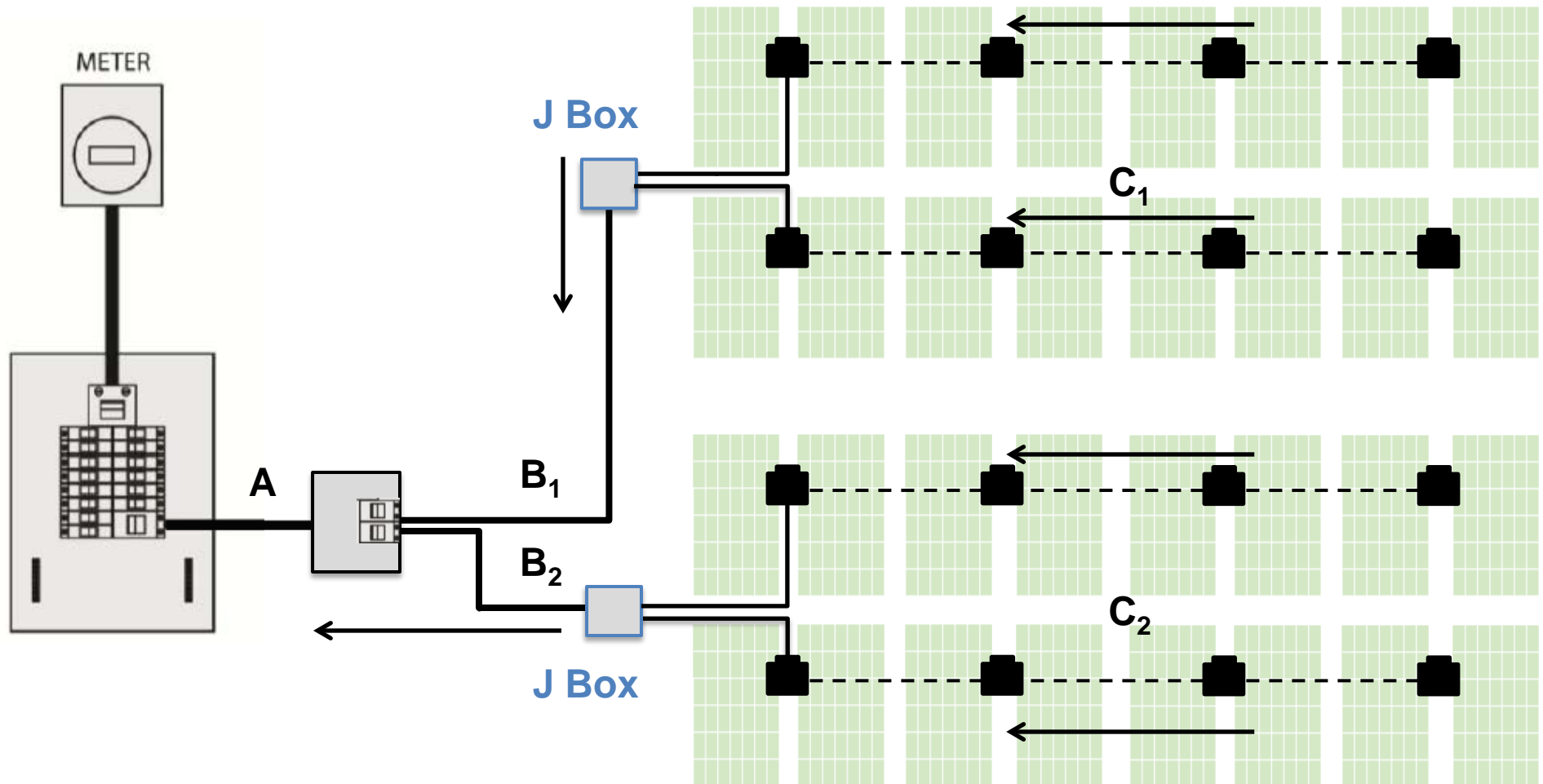

Two fully populated branch circuits equals 16A @ 240V for "B" and 32 A for "A"
Center tapping allows "B" up to ~100' (10AWG) and "C" up to 10" (8 AWG)

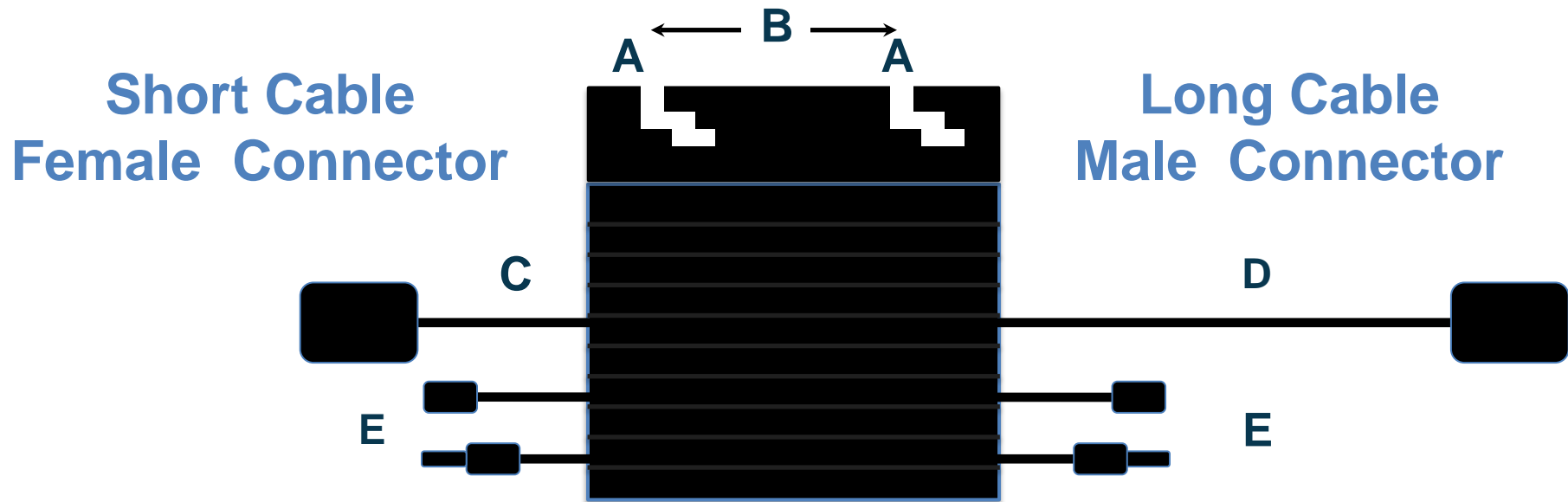

- A 0.3" (7.62mm) gap
- B 4.7" (120mm) center-to-center
- C 7.5" (190.5mm) long
- D 70.9" (1800mm) long
- E 7.4" (188mm) long

3 m Jumper



Male and Female End Caps

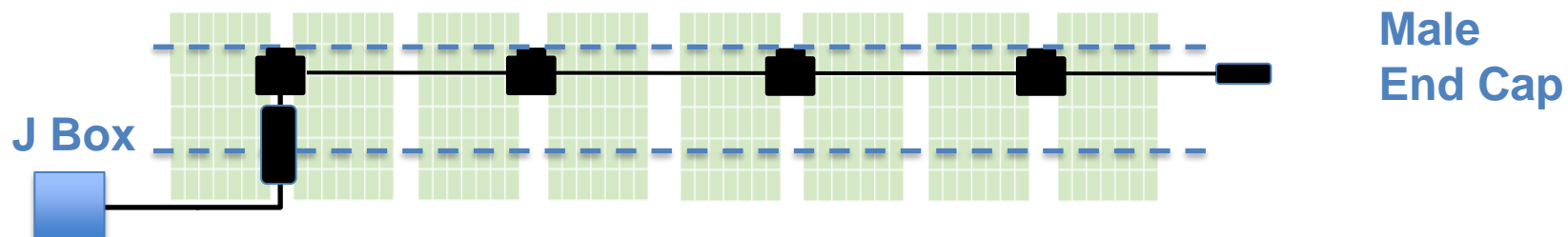

If the short cable (female) is to terminate into the J-box, you will need a male jumper and male end cap to complete the branch.

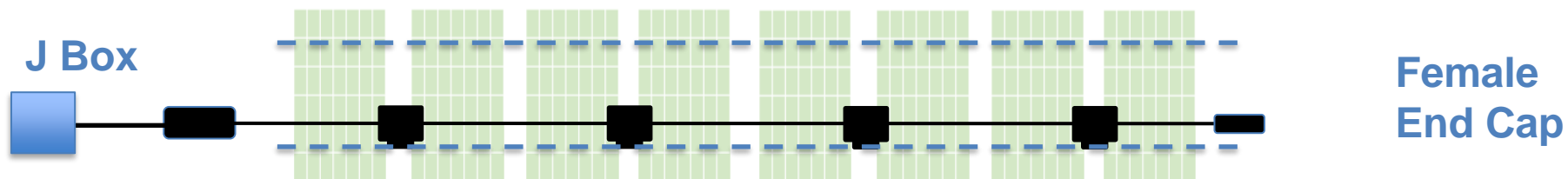

If the long cable (male) is to terminate into the J-box, you will need a female jumper and female end cap to complete the branch.

In addition to spanning gaps, the LSMFJ-3.0 jumper can be cut in half to form a male and female pigtail pair.



Male Pigtail



Female End Cap 

3 m Jumper



J Box

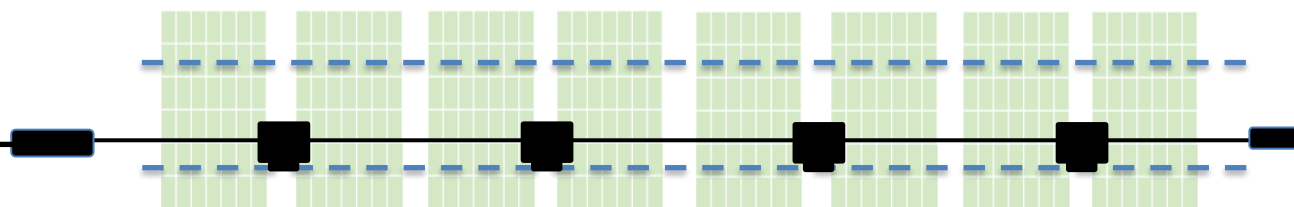

Female End Cap

Use a pigtail to connect the long cable (male) into the J-box. Terminate the branch end with a female end cap.

Female End Cap

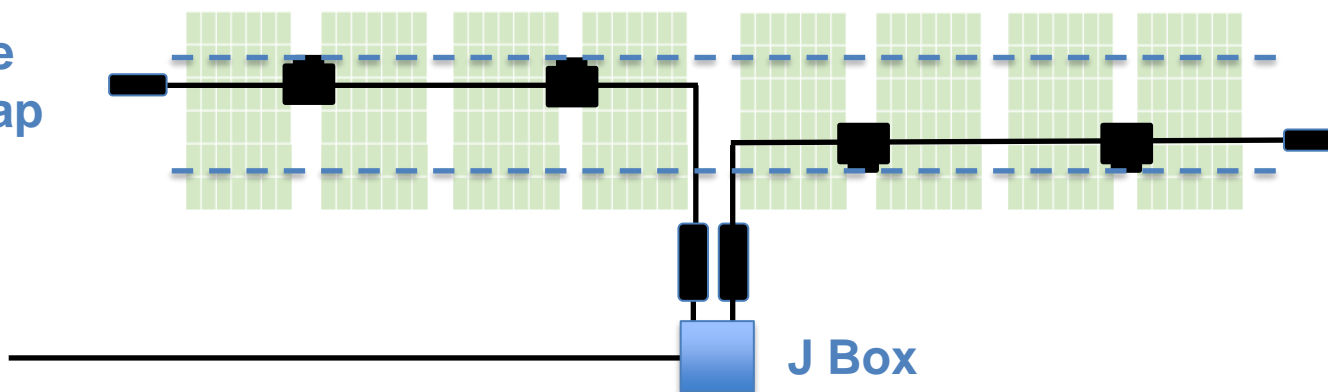

Female End Cap

To center tap, use two pigtails to connect the long cables (male) into the J-box. Terminate each branch end with a female end cap.

Link™ Gateway Installation

- Used with PLC communication devices
- Link™ Gateway installed in series with array
- Supports up to 50A thru current (16-25 micros)
- Gateway should be placed ≤ 200 ft from micros

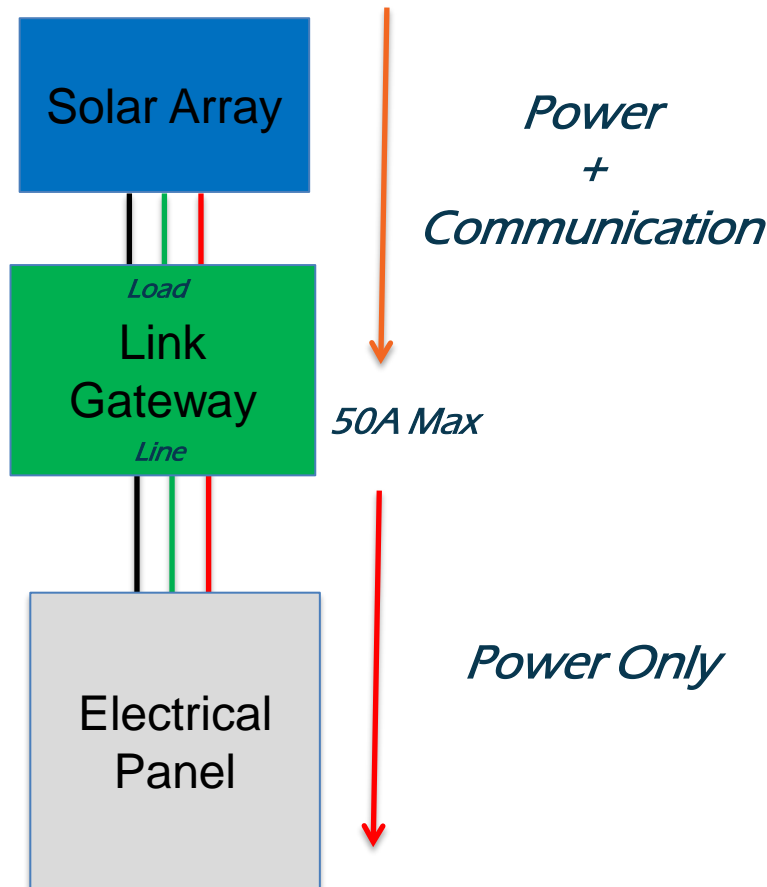

- Digi™ Gateway installed in parallel to array
- Supports up to 100+ micros
- Up to 100' (30 m) separation micro-micro
- Up to 250' (75 m) separation micro-gateway

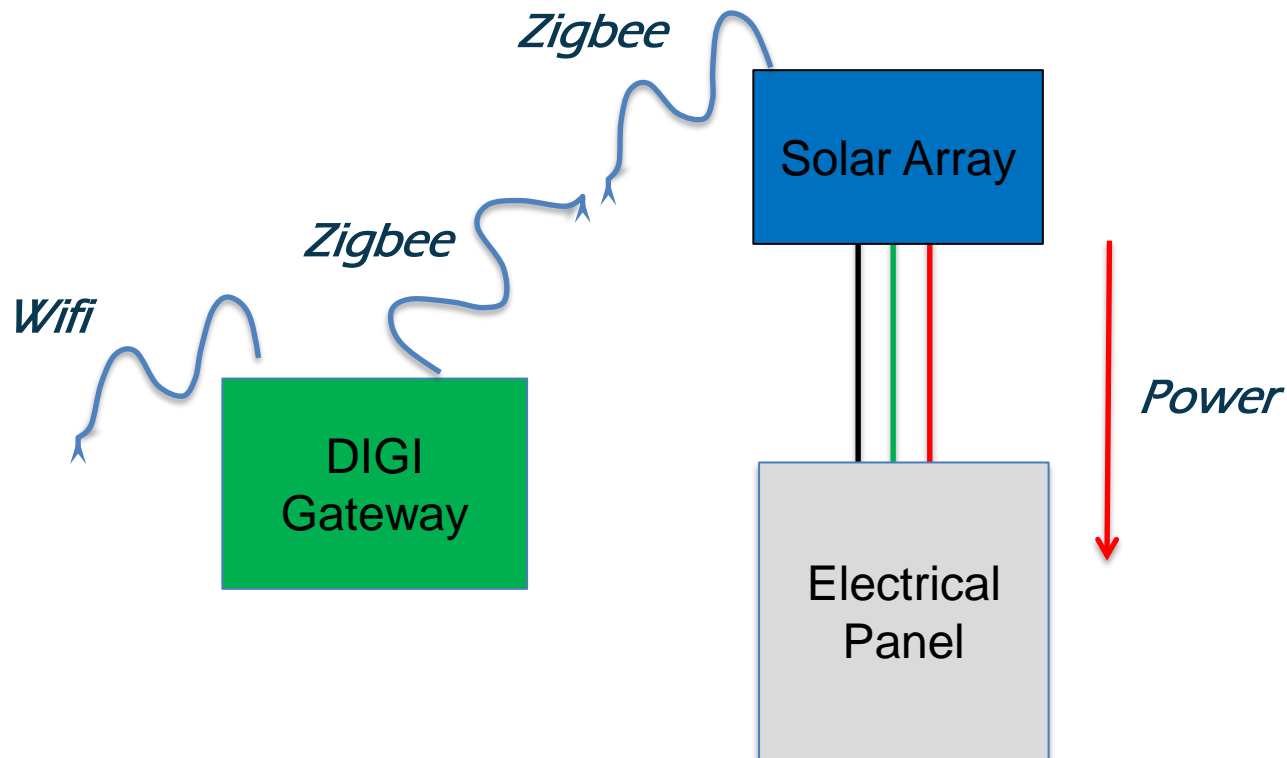

LeadSolar Technical Support:

Robert Garton- Director of Technical Services

rgarton@leadsolarenergy.com

(888) 405-2860 option 2

(818) 213-5512